

**1-ALWAYS CONNECT THE HEAD-UNIT CABLE ADAPTER 1st before ignition is turned on!**

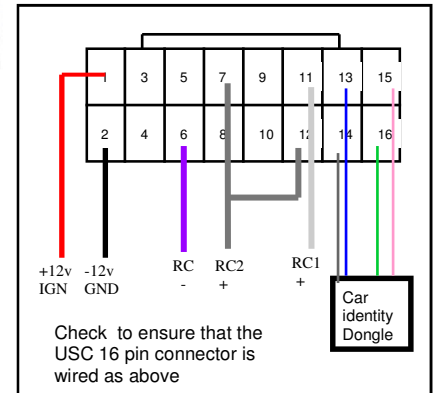

1. Choose a head-unit adapter from the list overleaf and connect it to the USC black box.
2. Turn off the ignition supply to the car!
3. Remove the OEM head-unit, Connect car the audio connectors and mate with the connectors supplied with the 29 series cable.
4. The Three loose wires must be connected to the 16 way data connector in the car exactly in the positions marked A, B & C. Ignore other wires
5. Attach blue white wire to Amp remote turn on from new radio if car has amplifier
6. Check that the car has an EARTH supply at the car connector, if not attach black to ground.
7. Test unit before fully fitting radio and trims back.

29-645	Navara	Murano	X Trail	350Z
Pin3 White	Wire A = Pink/Silver	Green	Blue/Black	Yellow/Red or Red/Green
Pin5 Grey	Wire B = White/Silver	Green/White	Blue/Red	Grey/Red or Orange/Silver
Pin6 Purple	Wire C= BLUE/SILVER	Green/Black	Black/Brown	Grey/Red or Yellow/Green

**If Problems:** Check that correct adapter has been used and links are in the correct place. Always disconnect from the power supply if you change the head-unit adapter lead. Check that Red wire is 12V ignition and not Permanent power. Check that head-unit is earthed and black wire is earth. Check all connections are the same as the wiring diagram shown here

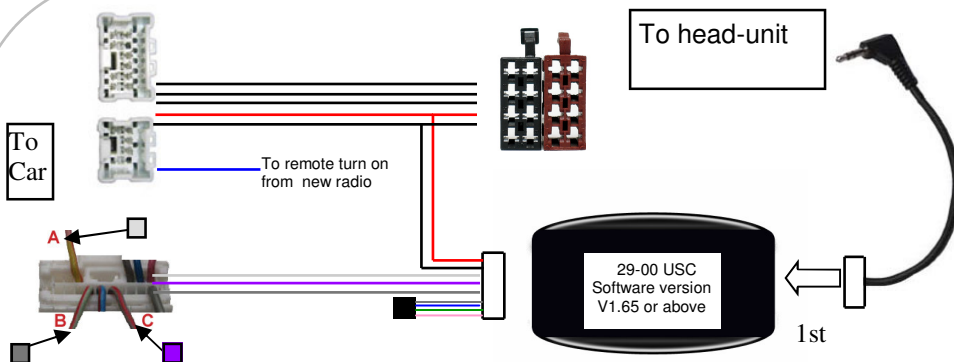

**1-ALWAYS CONNECT THE HEAD-UNIT CABLE ADAPTER 1st before ignition is turned on!**

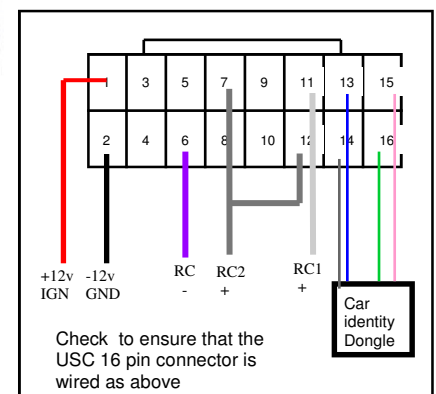

1. Choose a head-unit adapter from the list overleaf and connect it to the USC black box.
2. Turn off the ignition supply to the car!
3. Remove the OEM head-unit, Connect car the audio connectors and mate with the connectors supplied with the 29 series cable.
4. The Three loose wires must be connected to the 16 way data connector in the car exactly in the positions marked A, B & C. Ignore other wires
5. Attach blue white wire to Amp remote turn on from new radio if car has amplifier
6. Check that the car has an EARTH supply at the car connector, if not attach black to ground.
7. Test unit before fully fitting radio and trims back.

29-645	Navara	Murano	X Trail	350Z
Pin3 White	Wire A = Pink/Silver	Green	Blue/Black	Yellow/Red or Red/Green
Pin5 Grey	Wire B = White/Silver	Green/White	Blue/Red	Grey/Red or Orange/Silver
Pin6 Purple	Wire C= BLUE/SILVER	Green/Black	Black/Brown	Grey/Red or Yellow/Green

**If Problems:** Check that correct adapter has been used and links are in the correct place. Always disconnect from the power supply if you change the head-unit adapter lead. Check that Red wire is 12V ignition and not Permanent power. Check that head-unit is earthed and black wire is earth. Check all connections are the same as the wiring diagram shown here

CHOOSE THE CORRECT HEAD-UNIT ADAPTER FROM THOSE BELOW

29-001 Alpine

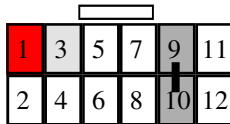

29-002 Blaupunkt

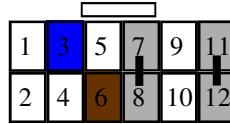

29-003 Clarion

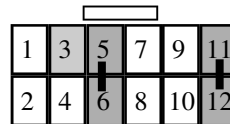

29-004 JVC

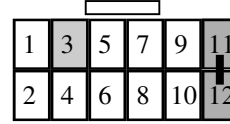

29-005 Kenwood  
Single wire

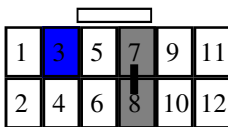

29-005D Kenwood  
4 pin DIN Plug

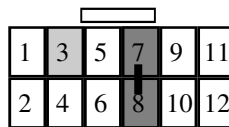

29-006 Panasonic  
Standard CD units

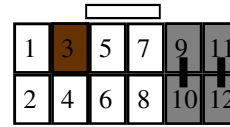

29-006A Panasonic  
AV head-units

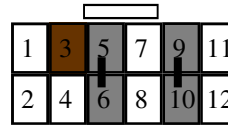

29-009 Siemens  
VDO

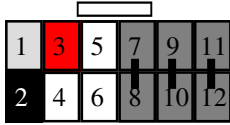

29-008 Sony  
3v & 5v units

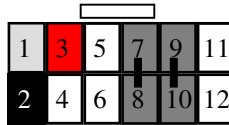

29-011 Zenec

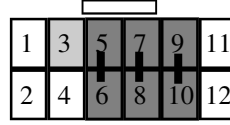

29-020 Pioneer &  
Sony

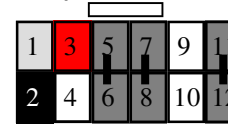

Special external drive  
PCB version

CHOOSE THE CORRECT HEAD-UNIT ADAPTER FROM THOSE BELOW

29-001 Alpine

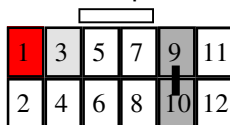

29-002 Blaupunkt

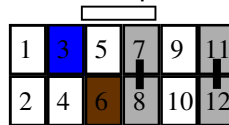

29-003 Clarion

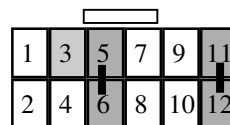

29-004 JVC

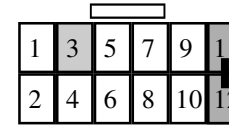

29-005 Kenwood  
Single wire

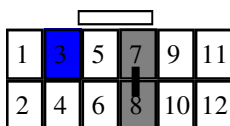

29-005D Kenwood  
4 pin DIN Plug

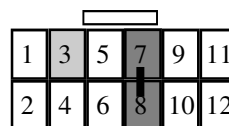

29-006 Panasonic  
Standard CD units

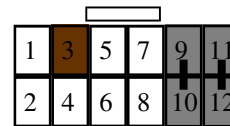

29-006A Panasonic  
AV head-units

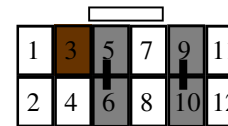

29-009 Siemens  
VDO

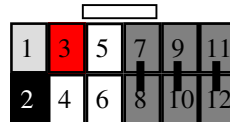

29-008 Sony  
3v & 5v units

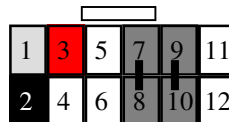

29-011 Zenec

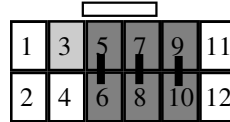

29-020 Pioneer &  
Sony

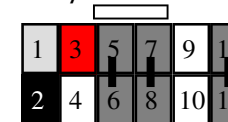

Special external drive  
PCB version